

WINTER

**INSTRUCTION MANUAL
CHEST FREEZER**

—— FA-170W

WARNING!

- Read all instructions before using the freezer.
DANGER or WARNING: Risk of child entrapment.
Child entrapment and suffocation are not problems of the past. Junked or abandoned freezer are still dangerous, even if they will “just sit in the garage a few days.”
- The appliance is not intended for use by persons (including children) with reduced physical, sensory or mental capabilities, or lack of experience and knowledge, unless they have been given supervision or instruction concerning the use of the appliance by a person responsible for their safety. Children should be supervised to ensure that they do not play with the appliance.
- If the power supply cord is damaged, it must be replaced by the manufacturer, its service agent or similarly qualified persons in order to avoid a hazard.
- Do not use mechanical devices or other means to accelerate the defrosting process, other than those recommended by the manufacturer.
- Never allow children to operate, play with, or crawl inside the freezer.
- Never clean freezer parts with flammable fluids. The fumes can create a fire hazard or explosion.
- Do not store or use gasoline or any other flammable vapors and liquids in the vicinity of this or any other freezer. The fumes can create a fire hazard or explosion.

Description of the Appliance

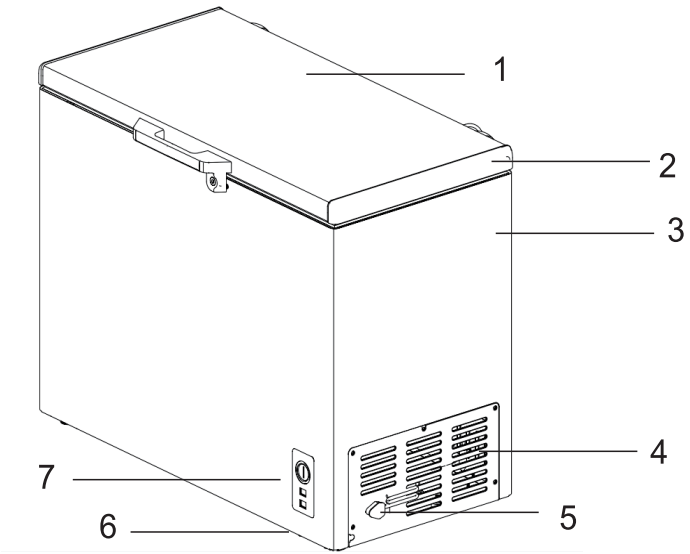

- 1. Door 2. Door frame 3. Cabinet 4. Ventilation grid**
5. Power cord 6. Wheel 7. Thermostat

(Picture shown for indicative purposes only, model supplied may differ).

CONTENTS:

Section 1. Installation

Section 2. Safety Advice

Section 3. Operating the Appliance

Section 4. Maintenance

Section 1. Installation

- This appliance is designed to be free standing only, and should not be recessed or built-in.
- Place your freezer on a floor that is strong enough to support the freezer when it is fully loaded.
- Allow 50mm of space between the back and sides of the freezer, which allows the proper air circulation.
- Locate the freezer away from direct sunlight and sources of heat (stove, heater, radiator, etc.).
- Direct sunlight may affect the acrylic coating and heat sources may increase electrical consumption. Extreme cold ambient temperatures may also cause the freezer not to perform properly.
- Avoid locating the freezer in moist areas.
- Plug the freezer into an exclusive, properly installed-grounded wall outlet. Do not under any circumstances cut or remove the third (ground) prong from the power cord. Any questions concerning power and/or grounding should be directed toward a certified electrician or an authorized service center.
- After plugging the appliance into a wall outlet, allow the unit to cool down for 2~3 hours before placing food in the freezer compartment.
- Connect the plug to an adjacent 13amp socket outlet and ensure that the appliance is not standing on the supply cable.
- This freezer requires a standard 220-240V~50Hz electrical outlet with three-prong ground.
- The “Green” light indicates that the freezer is properly connected to the electrical power. The light indicates power supply, and will glow even if the compressor has failed to work and the compartment is not being cooled.
- The “Red” light indicates that the compressor is on and running. The compressor should not, under normal conditions, be running continuously unless the unit is in “Super” mode.
- The door handle is put into the package of user manual .When installation ,please take out and fix it to the door with screw.
- The door key must be inserted on the lock, please place it where children cannot reach when not using in order to prevent children playing or lost.

Section 2. Safety Advice

- Please read this booklet thoroughly before installing and switching on the appliance. The manufacturer accepts no responsibility for incorrect installation and usage.
- Your old appliances contain insulation gases and refrigerant that must be disposed of correctly. Please ensure that the refrigerant circuit is not damaged before the appliance is taken away for correct disposal in line with current legislation. If there is any doubt contact your Local Authority for instructions.
- This appliance is a natural gas with a high level of environmental compatibility; however, caution is required as isobutene is a flammable gas.
It is essential to ensure that refrigerant tubes are not damaged during transportation and the installation of the appliance. In the event that the refrigerant circuit is damaged, avoid naked flames or sources of ignition and ventilate the room in which the appliance is situated.
- If using an adaptor, this must be used in accordance with the manufacturers instructions and ensure that the electrical circuit is not overloaded as this could cause overheating.
- Do not twist or bend the cables, and keep them away from hot surfaces.
- Do not plug in or unplug this appliance with wet hands.
- Following installation make sure that the power cable is not trapped underneath the appliance.
- Ensure the appliance is left in an upright position for at least 4 hours before you switch it on.
- The appliance has to be unplugged after use and before carrying out user maintenance on the appliance.

Section 3. OPERATING YOUR FREEZER

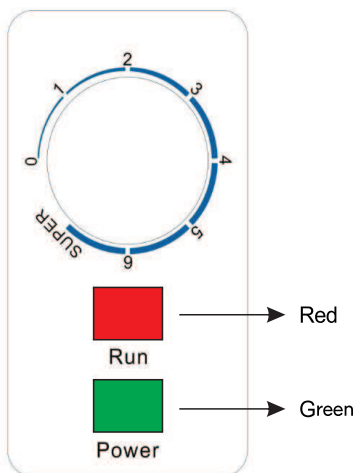

3.1. Temperature Control

- The temperature inside the chest freezer is adjusted by the knob.
- The number "0,1,2,3,4,5,6" on the control panel does not indicate the temperature degrees, but means different temperature levels.
- The smaller number selected, the higher temperature is. The bigger number selected, the lower temperature is. No.3 level is mostly used in normal situation.

3.2. NOTE

- Adjust the thermostat to "super" position; the chest freezer will proceed the fast frozen function. At this time, the compressor keeps working without stop. After fast frozen for some time(not more than four hours),this function should be stopped.
- If the unit is unplugged, lost power, or turned off; you must wait 3 to 5 minutes before restarting the unit. If you attempt to restart before this time delay, the freezer will not start.
- Large amounts of food will lower the cooling efficiency of the appliance.
- If you choose to change the thermostat setting, adjust thermostat control by one numerical increment at a time. Allow several hours for temperature to stabilize between adjustments.
- After power on, the indicator lamp (green color) will keep lighting.
- The red color lamp will keep on or off according to the compressor working on or off. When the red lamp is on, the compressor is working, When red lamp is off, the compressor is not working.

3.4. Defrosting Your Freezer

- When? For the most efficient operation and minimum energy consumption, defrost the freezer when the frost on the freezer walls is excessive or ¼ to ½ inch thick.
- Choose a time when the stock of frozen food is low.

Section 4. CARE AND MAINTENANCE

4.1. Cleaning Your Freezer

- Upon installation of your new appliance, it is recommended that it be cleaned thoroughly.
- Unplug the freezer, remove the food and storage basket.
- Wash the inside with a damp warm cloth containing a water and baking soda solution.
- The solution should be about 2 tablespoons of baking soda to a quart of water.
- Wash the storage basket with a mild detergent solution.
- Be sure to keep the door gasket (seal) clean to keep the unit running efficiently.
- The outside of the freezer should be cleaned with mild detergent and warm water.
- Dry the interior and exterior with a soft cloth.
- The condenser coils should be vacuumed when they are dusty or dirty.
- It is recommended that the unit be cleaned each time it is defrosted to help keep the unit odor free and running efficiently.

4.2. Vacation Time

- Remove all the food.
- Unplug the freezer.
- Clean the freezer.
- Leave the door open slightly to avoid possible formation of condensation, mold, or odors.
- Use extreme caution in the case of children. The unit should not be accessible to child's play.
- Short vacations: Leave the freezer operating during vacations of less than three weeks.
- Long vacations: If the appliance will not be used for several months, remove all food and unplug the power cord. Clean and dry the interior thoroughly. To prevent odor and mold growth, leave the door open slightly; blocking it open if necessary or have the door removed.

4.3. Moving Your Freezer

- Remove all the food.
- Securely tape down all loose items inside your freezer.
- Remove the rollers to prevent damage.
- Tape the doors shut.
- Be sure the freezer stays in the upright position during transportation.

4.4. Energy Saving Tips

- The freezer should be located in the coolest area of the room, away from heat producing appliances or heating ducts, and out of the direct sunlight.
- Let hot foods cool to room temperature before placing in the freezer. Overloading the freezer forces the compressor to run longer. Foods that freeze too slowly may lose quality, or spoil.
- Be sure to wrap foods properly, and wipe containers dry before placing them in the freezer. This cuts down on frost build-up inside the freezer.
- Freezer storage bin should not be lined with aluminum foil, wax paper, or paper toweling. Liners interfere with cold air circulation, making the freezer less efficient.
- Organize and label food to reduce door openings and extended searches. Remove as many items as needed at one time, and close the door as soon as possible.

4.5. Changing the Interior Light

- Switch off the power supply to the appliance
- Remove the plastic light cover
- Remove the lamp from the light unit.
- Replace the lamp with a suitable replacement (10W)
- Refit the cover and switch the appliance back on.

4.6. PROBLEMS WITH YOUR FREEZER

- You can solve many common freezer problems easily, saving you the cost of a possible service call.
- Try the suggestions below to see if you can solve the problem before calling the servicer.

THE GRIP HANDLE SHOULD BE ASSEMBLED AS FOLLOWS

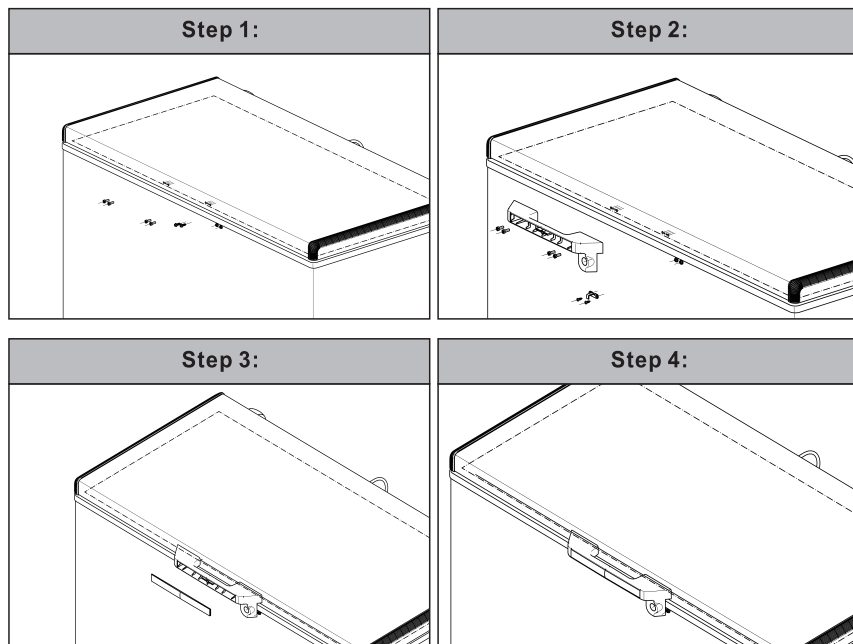

(Picture shown for indicative purposes only, model supplied may differ).

TROUBLESHOOTING GUIDE

Freezer does not operate.

- Not plugged in.
- The circuit breaker tripped or a blown fuse.
- The freezer temperature control is set at "0~6".

Compressor turns on and off frequently.

- The room temperature is hotter than normal.
- A large amount of food has been added to the freezer.
- The door is open too often.
- The door is not closed completely.
- The temperature control is not set correctly.
- The door gasket does not seal properly.
- The freezer does not have the correct clearances.
- The freezer has recently been disconnected for a period of time.
- Four hours are required for the freezer to cool down completely.

Temperature inside the freezer is too warm.

- Temperature control is set too warm. Turn the control to a cooler setting and allow several hours for the temperature to stabilize.
- Door is kept open too long or is opened too frequently. Warm air enters the freezer every time the door is opened. Open the door less often.
- The door is not closed completely.
- The door gasket does not seal properly.
- A large amount of warm or hot food might have been stored recently. Wait until the freezer has had a chance to reach its selected temperature.
- The freezer has recently been disconnected for a period of time. Four hours are required for the freezer to cool down completely.

Temperature inside the freezer is too cold.

- Temperature control is set too cold. Turn the control to a warmer setting and allow several hours for the temperature to stabilize.
- Fast Freeze switch is turned on. This causes continuous running of the compressor and bypasses the temperature control.

Temperature of external freezer surface is warm.

- The exterior freezer walls can be as much as 30F warmer than room temperature.
- This is normal while the compressor works to transfer heat from inside the freezer cabinet.

Popping or cracking sound when compressor comes on.

- Metal parts undergo expansion and contraction, as in hot water pipes.
- This is normal. Sound will level off or disappear as freezer continues to run.

Bubbling or gurgling sound, like water boiling.

- Refrigerant (used to cool freezer) is circulating throughout the system. This is normal.

Vibrations.

- Check to assure that the freezer is on a level surface.
- Floor is uneven or weak. Freezer rocks on the floor when it is moved slightly.
- Be sure floor can adequately support freezer.
- Level the freezer by putting wood or metal shims under part of the freezer.
- The freezer is touching the wall. Re-level the freezer and move it from the wall.
- See "Installation Instructions".

Moisture forms on inside freezer walls.

- Weather is hot and humid, which increases internal rate of frost build-up.
- This is normal.
- Door is slightly open.
- Door is kept open too long, or is opened too frequently.
- Open the door less often.
- The door is not sealed properly.

Moisture forms on outside of freezer.

- Door is slightly open, causing cold air from inside the freezer to meet warm moist air from outside.

The door will not close properly.

- The freezer is not on a level surface.
- The gasket is dirty.
- The storage basket is out of position.

Insurance

**! Any warranty provided with this product does not cover loss of !
fridge/freezer content.**

Any claim for loss, damage, costs or expenses of an indirect or consequential nature including any economic loss or damage to foodstuffs or any other goods is excluded. We recommend that you inspect your fridge/freezer regularly to check that it is working correctly, losses can result from deterioration following breakdown or accidental failure of the appliance, fuses, plugs or public electricity supply, these can be covered by your standard home insurance or might require extra cover. Check with your insurance provider.

Important Note:

This appliance is marked according to the European directive 2002/96/EC on Waste Electrical and Electronic Equipment (WEEE). By ensuring this product is disposed of correctly, you will help prevent potential negative consequences for the environment and human health, which could otherwise be caused by inappropriate waste handling of this product.

The symbol on the product, or on the documents accompanying the product, the Crossed Out Wheelie Bin, indicates that this appliance may not be treated as household waste. Instead it shall be handed over to the applicable collection point for the recycling of electrical and electronic equipment.

Disposal must be carried out in accordance with local environmental regulations for waste disposal. For more detailed information about treatment, recovery and recycling of this product, please contact your local authority, your household waste disposal service or the retailer where you purchased the product.



We continuously try to improve our products for the benefit of our customers. For this reason we reserve the right to make changes to any product at any time, without notice

Specification, picture and feature are subject to change without prior notice for purpose of product improvement.